



Kristin, Statoil



Draugen, Shell

SINTEF's EFFORT Project

Energy Efficiency in Offshore Oil and Gas Production

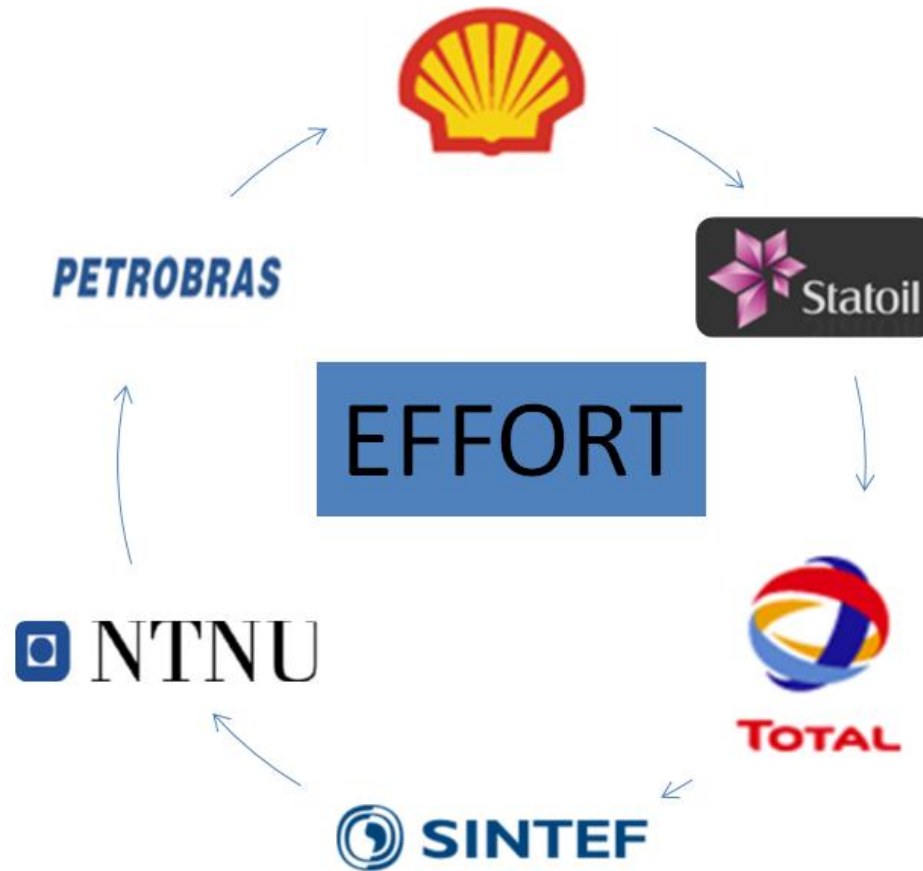

Funded by the Research Council of Norway and the EFFORT partners
Budget: 27.6 mill NOK, project duration: 2010-2014

Background

- Increasing focus on **CO₂ emissions** from offshore operation
 - 9.8 million tons of CO₂ emissions from gas turbines, flaring 1.4 million tons, other 0.6 million tons(2010)
- **Extensive energy need in offshore oil**
 - Export of gas and oil
 - Oil and gas processing
 - Driving compressors
 - Drilling
 - Power production
- Energy need covered by gas turbines and boilers
 - **Room for improving efficiency**

**CO₂ Emissions from Offshore Operations
Source Distribution (2010)**
From Department of Oil and Energy, Facts, 2011

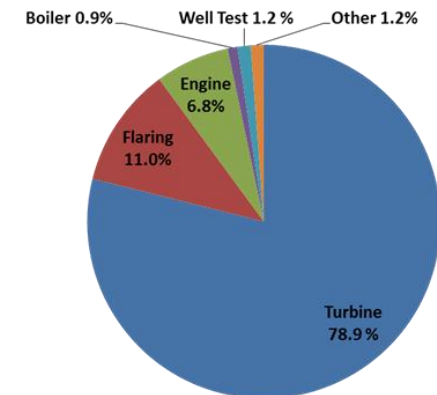

Goal of EFFORT

- Develop **Energy Efficient** technologies and solutions for offshore oil and gas production
- Promote **Implementation** of the technologies offshore



Reduced GHG
Emissions and
Energy Use

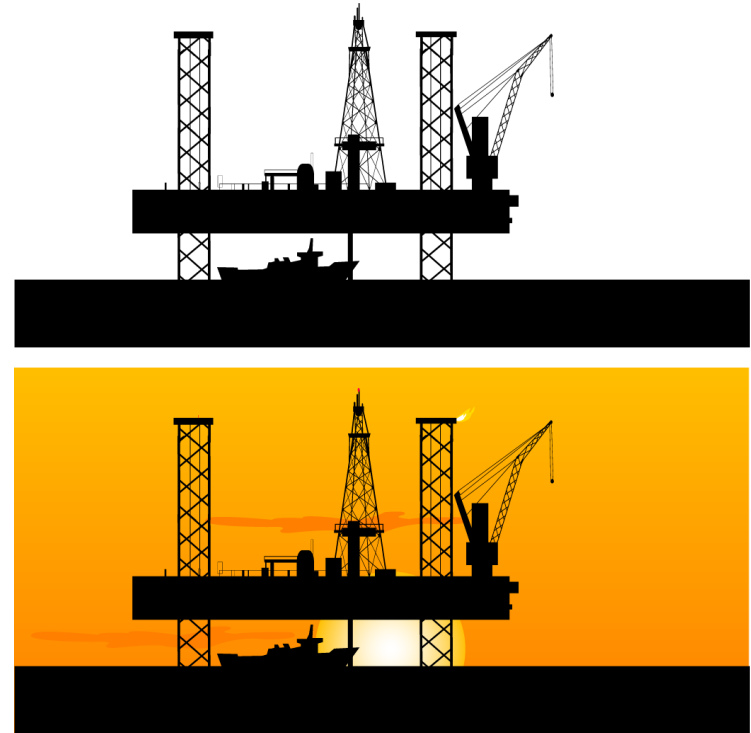

EFFORT Objectives

- Develop knowledge and tools for Offshore Accommodated Technologies:
 - Compact bottoming cycles
 - Power production from surplus heat sources
- Enable implementation of new technology through research focused on the offshore-specific requirements, i.e.:
 - Low weight, compact size and flexible layout
 - Robust operation; reliable and with low maintenance requirements
 - Safe working fluids with minimum environmental impact
 - Systems that require a minimum of modifications and shut-down time for retrofit and installation
- Focus on Energy Efficiency
 - Energy recovery, heat and energy utilisation for power production and other purposes
 - Stationary, transient and during the lifetime of the field
- Identify demonstration opportunities for the most promising technologies
- Disseminate knowledge and know-how on existing and emerging technologies
- Educate and train one Ph.D. and one post doc. candidate

Compact Bottoming Cycles

Compact bottoming cycles utilising steam, CO₂, or hydrocarbons

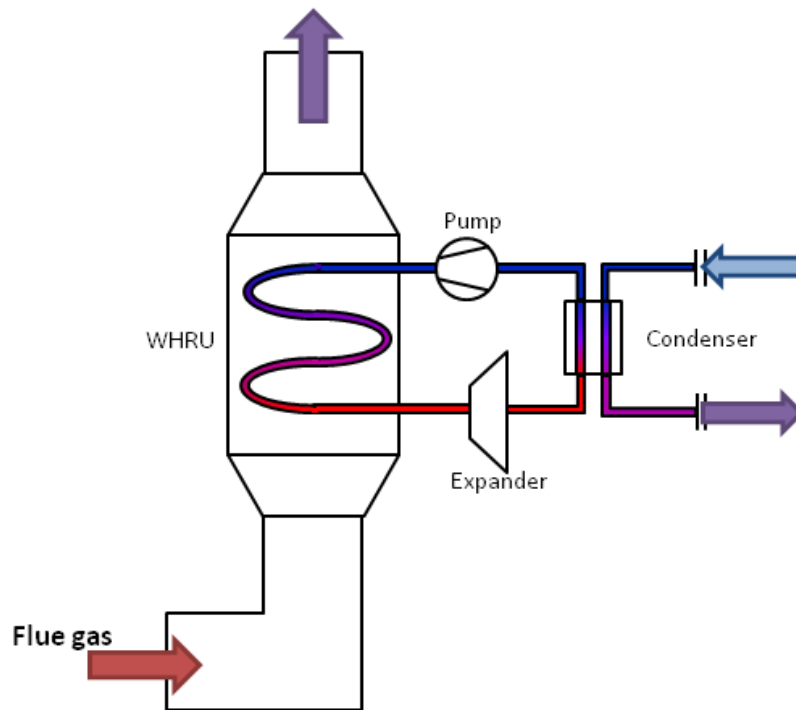

Power Production from Surplus Heat Sources: Compressed Gas

- Low temperature heat source
- High pressure -> compact HX
- Rankine Cycle
 - Subcritical hydrocarbon
 - Transcritical CO₂ or hydrocarbon

